

Mini-Needle Valves Type 910.11.100

WIKA Datasheet 910.11.100

Applications

Intended to isolate the pressure gauge from the measured fluid or to provide a means of throttling or dampening pressure pulsation.

Pressure Rating

Brass: 6,000 PSI
Steel / 316SS 10,000 PSI

Operating Temperature

Media: max. 200°F (+93°C)
min. 0°F (-18°C)

Flow Rate

Hard seat models Max. $C_v = 0.42$



Mini-Needle Valve 910.11.100 - brass min-valve shown with knurled knob standard.

Standard features

Valve Body

360 Brass, 12L14 nickel-plated carbon steel, or electro-polished 316 stainless steel

Bonnet

360 Brass, 12L14 carbon steel or 316 stainless steel

Valve Stem

360 Brass or 316 stainless steel

Handle

360 Brass, 12L14 carbon steel or 316 stainless steel.
Brass mini-valves supplied with knurled knob standard.
Carbon steel and stainless steel mini-valves supplied with tee-handle.

Handle Bolt

360 Brass, 12L14 carbon steel or 18-8 stainless steel

Stem Seals

Viton o-ring with PTFE backup ring

Orifice Size

0.172 inches (4.37 mm)

Standard Threaded Connection Size

1/8" NPT or 1/4" NPT

Order Options

Alternate threaded connection

Dimensions

Female - Female

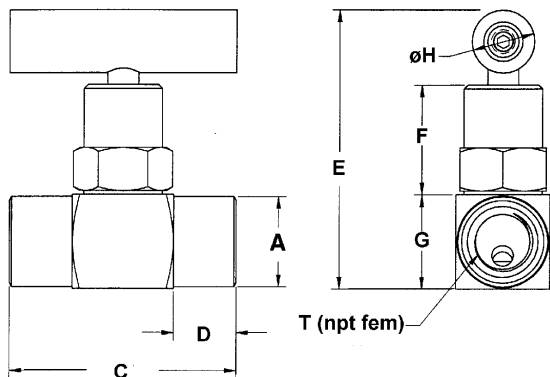

Male - Female

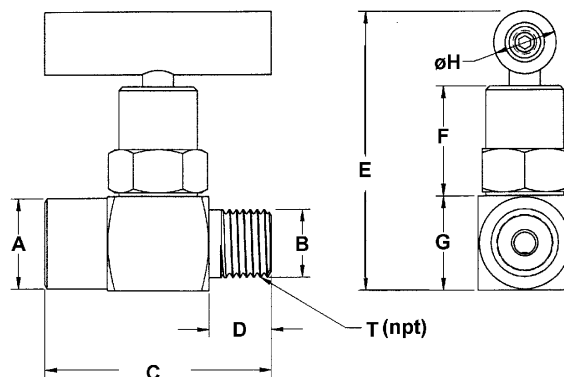

Male - Male

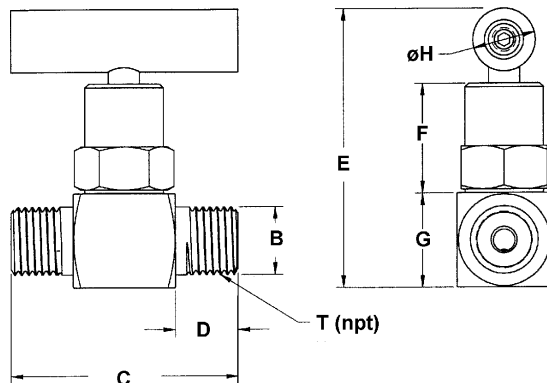

TYPE	WEIGHT	KEY	A	B	C	D	E	F	G	H	T
Type 910.11 Mini Fem. - Fem.	0.4 lbs	mm	18.3	--	46	12.7	63	22	19	12.7	1/4"
		in.	0.72	--	1.81	0.50	2.48	0.88	0.75	0.50	
Type 910.11 Mini Male - Fem. *	0.4 lbs.	mm	18.3	13.7	46	12.7	63	22	19	12.7	1/4"
		in.	0.72	0.54	1.81	0.50	2.48	0.88	0.75	0.50	
Type 910.11 Mini Male - Male	0.4 lbs.	mm	--	13.7	46	12.7	63	22	19	12.7	1/4"
		in.	--	0.54	1.81	0.50	2.48	0.88	0.75	0.50	

* Flow direction of media is from male to female connection.

Ordering information
 Pressure gauge model / Nominal size / Scale range / Size of connection / Optional extras required
 Specifications and dimensions given in this leaflet represent the state of engineering at the time of printing.
 Modifications may take place and materials specified may be replaced by others without prior notice.



WIKA Instrument Corporation
 1000 Wiegand Boulevard
 Lawrenceville, GA 30043
 Tel (770) 513-8200 Toll-free 1-888-WIKA-USA
 Fax (770) 338-5118
 E-Mail info@wika.com
 www.wika.com