

Pneumatic hand test pump Model CPP7

WIKA data sheet CT 91.04

Applications

- Simple test pressure generation on-site, in the laboratory or in the workshop
- Supply of small positive or negative pressures
- Specifically for the testing, adjustment and calibration of low-pressure measuring instruments in the areas of: heating, ventilation and air conditioning, clean room engineering, medical engineering and filtration and dust removal technology

Special features

- Switchable pressure/vacuum generation
- Precise setting through the fine-adjustment valve
- Simple and ergonomic handling
- Compact dimensions
- Low weight

Description

Application areas

Test pumps serve as pressure generators for the testing, adjustment and calibration of mechanical and electronic pressure measuring instruments through comparative measurements. These pressure tests can be carried out statically in the laboratory or workshop, or on site at the measuring point.

Easy operation

If one connects the test item and a sufficiently-accurate reference measuring instrument to the hand test pump, on actuating the pump, the same pressure will act on both measuring instruments. By comparison of the two measured values at any given pressure value, a check of the accuracy and/or adjustment of the pressure measuring instrument under test can be carried out. In order to approach the set-point exactly, the hand test pump features a fine-control valve.



Model CPP7 hand test pump

Easy handling

The CPP7 is a pneumatic hand test pump for low-pressure ranges up to 7 bar, with switching to vacuum generation down to -850 mbar. The maximum pressure or vacuum achievable is dependent on the connected test volume.

Through the smooth pressure generation and the integrated fine-adjustment valve, very small positive or negative pressures in the mbar range can be set safely and precisely.

Via a T-connector with a hose connection, the test item and the reference measuring instrument can be easily connected.

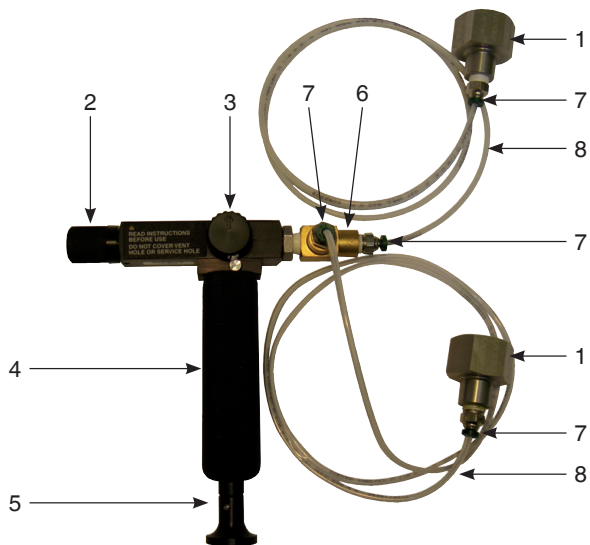

- 1) Pressure connections for reference measuring instrument and test item, G 1/2 female
- 2) Fine-adjustment valve
- 3) Pressure relief valve and switching between pressure or vacuum generation
- 4) Pump handle
- 5) Ram
- 6) T-connector 2 x 1/8 NPT female to 1/8 NPT male
- 7) Hose connection adapter 1/8 NPT male to 1/8 quick connection
- 8) Hose assembly for test item connector, (length 1 m)

Specifications	Model CPP7
Pressure range	-0.85 ... +7 bar
Medium	Air
Pressure connections	1 connection with 1/8 NPT female thread to the pump body, prepared for connection to a T-connector with 2 hoses and G 1/2 female threads
Fine-adjustment	Fine-adjustment valve
Dimensions in mm (L x W x H)	160 x 115 x 40 mm without T-connector 160 x 160 x 45 mm with T-connector
Weight	270 g without T-connector 340 g with T-connector

Hand test pump ordering information**Order no.**

CPP7 hand test pump incl. connection adapters	14030908
CPP7 hand test pump incl. case and connection adapters	14030847

Accessories order information**Order no.**

Plastic case, incl. foam insert for CPP7; Dimensions in mm: (W/H/D) 350 x 265 x 85	14030848
Hose connection adapter 1/8 NPT male to 1/8 quick connector	14030849
T-connector 2 x 1/8 NPT female to 1/8 NPT male, material: brass	14030850
Connection adapter, 1/8 NPT female to G 1/2 female, material: stainless steel	14030851
Connection adapter, 1/8 NPT female to G 1/4 female, material: stainless steel	14030852
Spare hose for CPP7, length 1 m	14030853

Scope of delivery

- Model CPP7 hand test pump
- T-connector
- 4 hose connection adapters
- 2 connection tubes (each 1 m long)
- 2 connection adapters to G 1/2 female threads
- 2 seals
- PTFE sealing tape



Model CPP7 hand test pump in transport case incl. standard accessories



Application, calibration with model CPP7 hand test pump and model CPH6200 reference measuring instrument

Recommended reference pressure measuring instruments:**Precision digital pressure gauge model CPG1000**

Measuring ranges: 0 ... 0.07 bar up to 0 ... 700 bar and vacuum

Accuracy: 0.05 % of span

For further specifications see data sheet CT 10.01

**Hand-held pressure indicator model CPH6200**

Measuring ranges: 0 ... 0.1 bar up to 0 ... 1,000 bar and vacuum

Accuracy: 0.2 % of span

For further specifications see data sheet CT 11.01

**ProcessCalibrator model CPH6000**

Measuring ranges: 0 ... 0.25 bar up to 0 ... 8,000 bar and vacuum

Accuracy: 0.025 % of span (<1,000 bar)

0.1 % of span (>1,000 bar)

For further specifications see data sheet CT 15.01

**Calibration software****EasyCal calibration software**

For inspection equipment monitoring incl. certificate generation and data storage

Specifications per data sheet CT 95.01

**Ordering information**

To order the described product the given order number is sufficient. Other options require additional specification.

© 2011 WIKA Alexander Wiegand SE & Co. KG, all rights reserved.
The specifications given in this document represent the state of engineering at the time of publishing.
We reserve the right to make modifications to the specifications and materials.



Mensor
201 Barnes Drive
San Marcos, Texas 78666
Tel. (512) 396-4200
Fax (512) 396-1820
E-mail Sales@mensor.com
www.mensor.com