

Differential Pressure Gauges Membrane Sensing Element Type 732.26 - Suitable for O2 Service

WIKA Datasheet 732.26

Applications

- For measurement in applications requiring low to medium differential and/or static process pressures.
- For cryogenic gases or corrosive environments with either liquid or gaseous media.

Product features

- External zero point adjustment
- Membrane sensing element
- Black powder-coated aluminum case
- 600 psid maximum working pressure
- Differential pressure ranges to 400 psid

Description

Nominal Sizes

4½" (115 mm)
6" (160 mm)

Accuracy (on increasing pressure)

± 1% of span

Scale Ranges

0/100 H₂O_d through 0/400 psid
(250 mbard through 25 bard)

Maximum Safe Working Pressure (Overpressure Safety)

600 psig (40 barg)

Operating Temperature

Ambient: -40 °F to +212 °F (-40 °C to +100 °C)
Media: max +100 °C (+212 °F)

Weather protection

NEMA 4X (IP66)



Differential Pressure Gauge Model 732.26 4½" & 6"

Standard features

Pressure connections

Standard:

1/4" NPT female, dual connections, top and bottom

Optional:

1/4" NPT female, back connection (panel mounting only, wall and pipe mounting bracket is not compatible with back connection).

1/2" NPT female, dual connections, top and bottom mount with adapters.

1/2" NPT female, back connection with adapters (panel mounting only; wall & pipe mounting bracket is not compatible with back connection).

Pressure connection markings

(+) High side connection

(-) Low side connection

Sensing Element (Wetted Parts)

Housing: 316L stainless steel

Membranes: 316L stainless steel / Inconel® 718 (NiCr-alloy)

O-rings: PTFE

Suitable for O2 service

Movement

Stainless steel

System Fill

Halocarbon oil

Dial Case

Black powder-coated aluminum

Bezel Ring

Stainless steel polished

Dial

Black aluminum with white lettering - standard

Pointer

White aluminum

Window

Polycarbonate

Standard Scale

in. H₂Od

Zero Adjustment

External through top of case

Mounting

Panel mounting kit is included. Wall or pipe mount kits are available as an option (for top/bottom connection only).

Warranty

Seven (7) years limited

Order Options (min. order may apply)

- White dial and black pointer
- Laminated safety glass window
- Stainless steel case
- Special connections
- Wall or pipe mounting kit
 - H-bracket, C-bracket
- Other pressure scales
- Hand written calibration test report

Size		A
4½"	mm	157.2
	in	6.19
6"	mm	204.3
	in	8.04

Optional Wall Mounting Kit (not compatible with optional back connections)

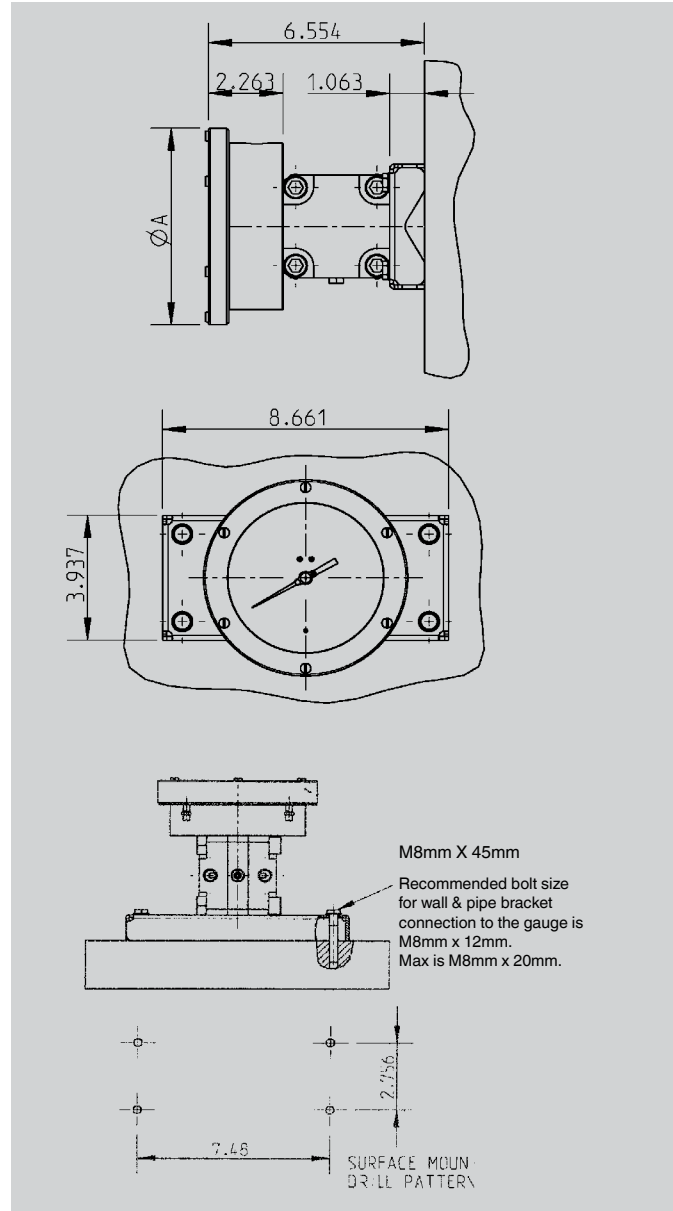

Optional Pipe Mounting Kit

(compatible only with top/bottom connections)

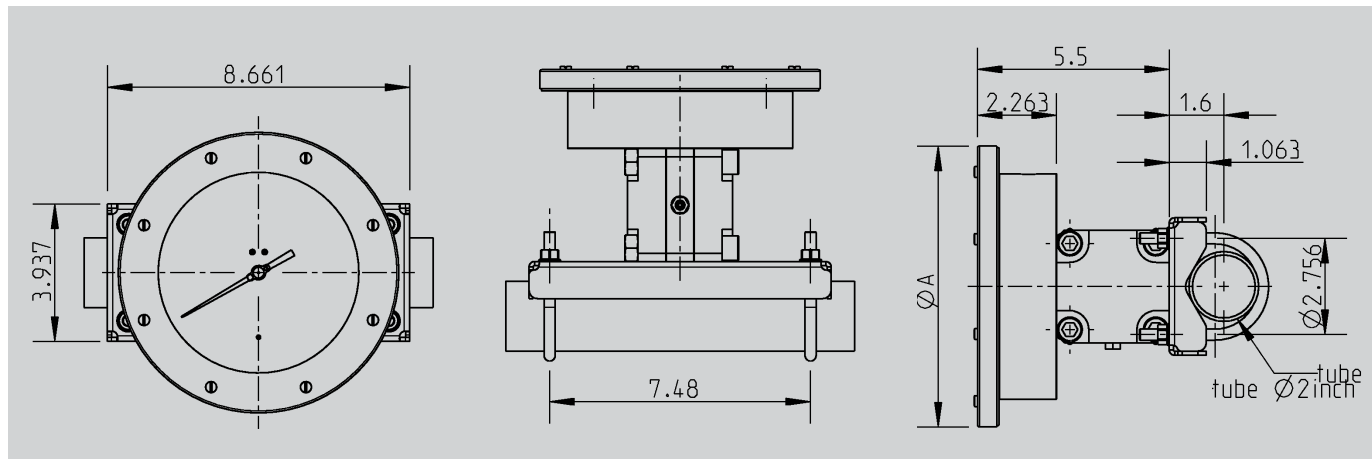

Type 732.26 Dimensions

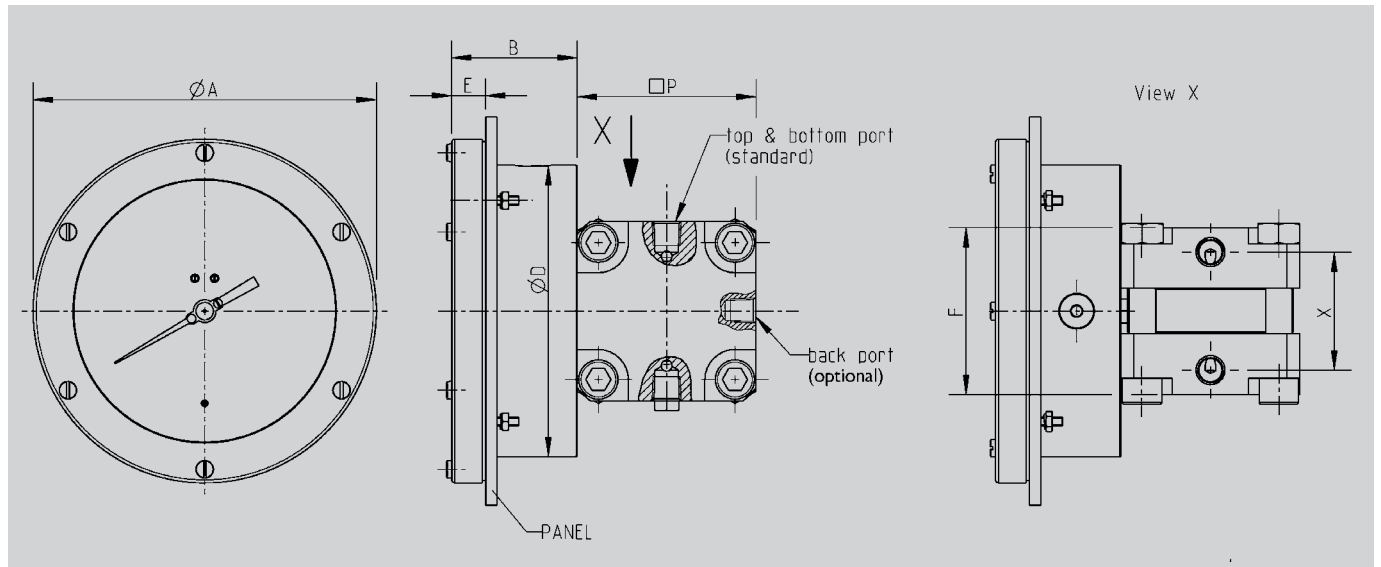

Size		$\varnothing A$	B	$\varnothing D$	E	F	$\square P$	X	Weight ¹
4½"	mm	157.3	57.5	133.4	25.1	80	82	54	10.15 lb. dry
	in	6.19	2.26	5.25	0.99	3.15	3.23	2.13	11.65 lb. filled
6"	mm	204.3	57.5	163.8	15.6	80	82	54	10.65 lb. dry
	in	8.04	2.26	6.45	0.61	3.15	3.23	2.13	12.95 lb. filled

¹ Weight without optional accessories

Zero Point Adjustment

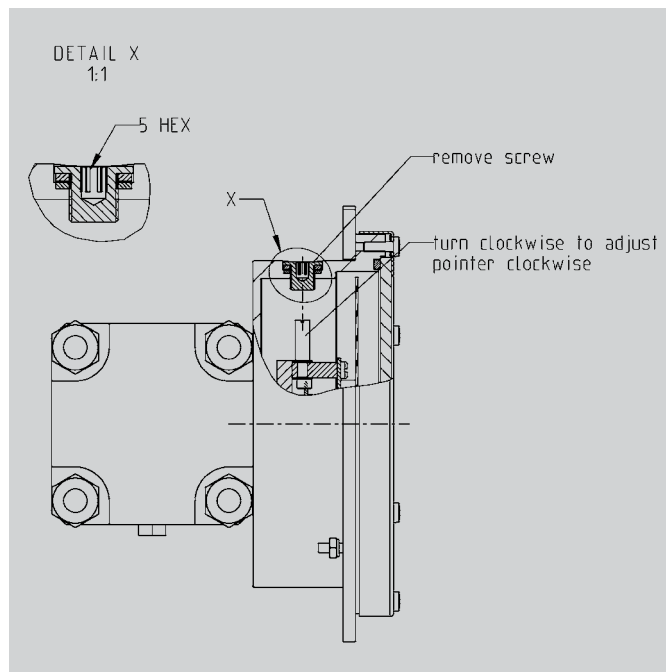

Panel Cut-out Dimensions

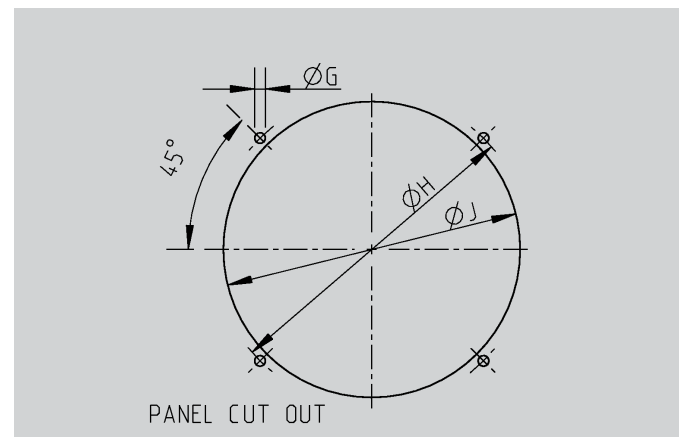

Size		$\varnothing G$	$\varnothing H$	$\varnothing J$
4½"	mm	4.8	143	134.3
	in	0.19	5.63	5.29
6"	mm	4.8	177.8	165
	in	0.19	7	6.5

Operating and Installation Instructions

Gauge Inspection:

Please read the product specification label attached to the gauge body to insure that this gauge is the same gauge specified for the particular application as it applies to dial size, materials of construction, working pressure, differential pressure, etc. Inspect for any damage and, if discovered, report it immediately.

Product Design Features:

The Type 732.26 Series is designed for working pressures to 600 psig and differential pressure to 400 psid. This series is supplied, standard, with a 6" dial or, optionally, with a 4.5" dial. The gauge has a 316L sensor cell, encapsulating opposed, high (+) and low (-) side SS/71B Inconel membranes in a Halocarbon liquid fill. The high (+) side pressure works against the membranes and the fill, causing them to move. This movement is transferred to a torque-tube assembly, linked to a horizontally moving, bidirectional overpressure valve (This valve protects the sensor membranes against damage from high (+) or low (-) side overpressure of the membranes in the sensor cell.) A torsion rod, located within the torque-tube assembly, passes through a sealed compression tube fitting (which isolates the sensor cell from the dial case assembly) into the dial case and is connected to the pinion/sector gear and pointer assembly. The twisting motion of the torsion rod, driven by the membrane movement, is magnified to a 270 Degree, linear arc and pointer travel.

Design and Operating Principle

- Process pressures p_1 and p_2 are applied to the chambers - (2) and + (3).
- Gauge head (4) is filled with liquid.
- Differential pressure across + and - pressure sides deflects the diaphragm (1) and displaces the liquid.
- The displacement of the connection rod (5) is converted through the use of a transmitting lever (6) into rotation, which is transferred over an axial shaft (7) to the movement (9).
- The torque pipe (8) seals, assuring a frictionless path.
- Overpressure protection in both directions up to the max. static pressure rating is provided by contoured metal bolsters.

Gauge Mounting:

The Type 732.26 Series gauge is supplied, standard, with four (4) threaded studs and locking nuts. The gauge is mounted in the panel from front to back and secured to the back of the panel with the threaded studs and locking nuts. Optional 2" pipe mount kit or wall mount kits are available (for units with top/bottom mount connections only).

Gauge Connections:

Standard dual (2) x 1/4" FNPT top/bottom connections with high (+) and low (-) connections clearly indicated. Optional connection sizes and/or back connections are available

Troubleshooting:

If the gauge is not indicating differential pressure, check to insure that both the high (+) and low (-) connections have been properly installed. Check to insure that there is differential pressure across the device being monitored by the Type 732.26 Series gauge. If the gauge is being used together with a three-valve manifold (recommended), check to insure that the high (+) and low (-) valves are in the open position and the equalizer valve is in the closed position. If, after following these steps with no positive result, please contact the Wika Customer Service Department or your nearest WIKA Distributor.

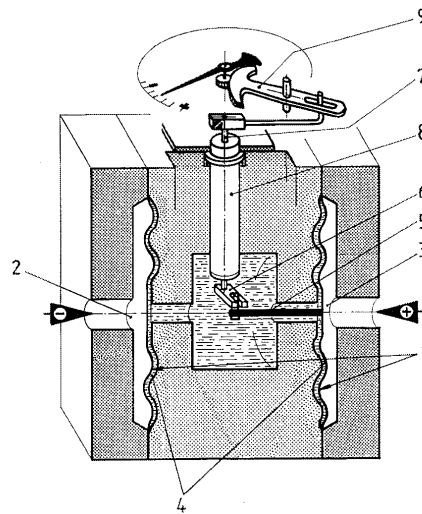

Ordering information

Pressure gauge model / Nominal size / Scale range / Size of connection / Optional extras required.
Specifications and dimensions given in this leaflet represent the state of engineering at the time of printing.
Modifications may take place and materials specified may be replaced by others without prior notice.



WIKAI Instrument, LP
1000 Wiegand Boulevard
Lawrenceville, GA 30043-5868
Tel: 888-WIKA-USA • 770-513-8200
Fax: 770-338-5118
E-Mail: info@wika.com
www.wika.com