

Bimetal Thermometer, Industrial Grade - All Stainless Steel Construction Type TI.53 - 5" Dial Size, Back Connected

Datasheet TI.53

Applications

- A wide range of applications including machine building, vessels, micro-brewing, boilers and water systems/piping
- Heating and air-conditioning technology (HVAC)
- Temperature measurement in harsh and aggressive environments

Product features

- Robust industrial design
- Back connection without external reset
- NEMA 4X (IP 66) weather protection

Specifications

Size

5" (127mm)

Accuracy

± 1.0% full scale value per ASME B40.3 Grade A

Ranges

From -100°F (70°C) to 1000°F (540°C)

From -50°C to 550°C (as single scale)

See table on page 2

Working Range

Steady: full scale value

Short time: 110% of full scale value

Over/Under Range Protection

≤ +500°F (+260°C): Temporary up to 50% of full scale

> +500°F (+260°C): Continuous to 800°F (+427°C)
Intermittant up to 1000°F (+538°C)

Connection

Material: 304 stainless steel

Center back mount (CBM) - Type TI.53

1/2" NPT Connection

Stem

Material: 304 stainless steel

Diameter: 1/4" (6.35 mm)

Length: 2½" to 24" (63.5 mm to 609.6 mm)

Measuring Element

Bi-metal helix



Thermometer TI.53

Dial

White aluminum, dished, with black markings

Case

Material: 304 stainless steel

Hermetically sealed

Weather protection NEMA 4X (IP 66)

Pointer

Black aluminum

Standard Scales

Single: Fahrenheit or Celsius

Dual: Fahrenheit (outer) and Celsius (inner)

Window Gasket

Neoprene

Silicone for ranges -100°F (-70°C) and
ranges > +550°F (+260°C)

Window

Flat instrument glass

Weight

16 oz. (454 g), not including the stem

Add 1 oz. (28 g) for every 2" (50 mm) of stem length

Dampening

Inert gel to minimize pointer oscillation

Warranty

Limited one year warranty as stated in WIKA's Terms & Conditions of Sale

Optional Extras

- Thermowells
- Special scales and dial markings
- Acrylic and safety glass windows
- Calibration certification traceable to NIST

STANDARD RANGES		
Fahrenheit Single Scale	Dual Scale F & C F Outer, C Inner	Celsius Single Scale
-100/150 F	-100/150 F & -70/70 C	-50/50 C
-40/120 F	40/120 F & -40/50 C	-20/120 C
0/140 F	0/140 F & -20/60 C	0/50 C ¹
0/200 F	0/200 F & -15/90 C	0/100 C
0/250 F	0/250 F & -20/120 C	0/150 C
20/240 F	20/240 F & -5/115 C	0/200 C
25/125 F	25/125 F & -5/50 C ¹	0/250 C
50/300 F	50/300 F & 10/150 C	0/300 C
50/400 F	50/400 F & 10/200 C	0/450 C ¹
50/550 F	50/500 F & 10/260 C	100/550 C ¹
150/750 F	150/750 F & 65/400 C	
200/1000 F ¹	200/1000 F & 100/540 C ¹	

¹ Not recommended for continuous service over 800°F (425°C)

Dimensions

Standard versions

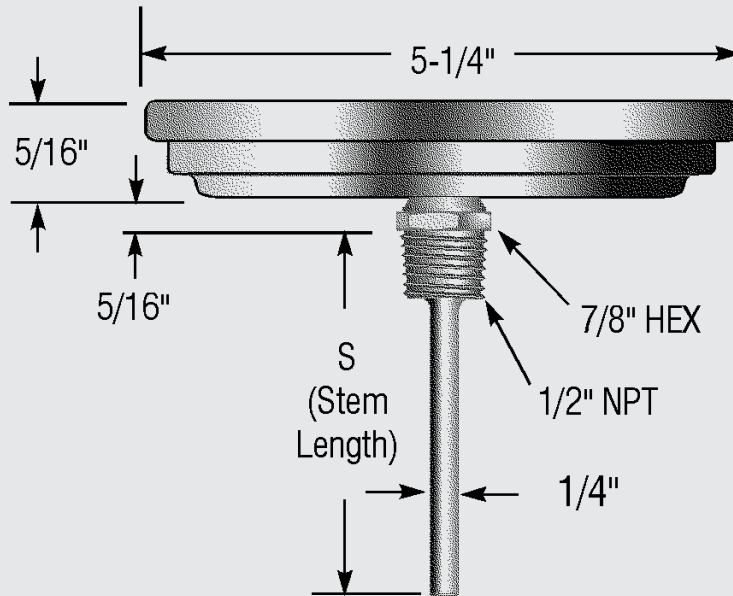

Back Connected Type TI.53

WIKA Type	DIAL SIZE	A	B	C	S (Stem Length)
53	5" (127 mm)	5-1/4" (8133.4 mm)	15/16" (23.8 mm)	5/16" (7.9 mm)	As Specified

Note: Thermowells for temperature instruments are recommended for all process systems where pressure, velocity, or viscous, abrasive and corrosive materials are present individually or in combination. A properly selected thermowell protects the temperature instrument from possible damage resulting from these process variables. Furthermore, a thermowell permits removal of the temperature instrument for replacement, repair or testing without effecting the process media or the system.

Ordering information

State computer part number (if available) /type number/size/range/connection size and locations/options required. WIKA reserves the right to make changes without prior notice.



WIKA Instrument Corporation
 1000 Wiegand Boulevard
 Lawrenceville, GA 30043
 1-888-WIKA-USA /770-513-8200 (in GA)
 Fax 770-338-5118
 info@wika.com www.wika.com