

Bourdon Tube Pressure Gauges

Stainless Steel Case, Process Gauge

Type 232.50 - Dry Case 4½"

Type 233.50 - Liquid-filled Case 4½"

WIKA Datasheet 23X.50 4.5

Applications

- With liquid-filled case for applications with high dynamic pressure pulsations (add restrictor) or vibration
- Suitable for corrosive environments and gaseous or liquid media that will not obstruct the pressure system
- Process industry: chemical/petrochemical, power stations, mining, on and offshore, environmental technology, mechanical engineering and plant construction
- Meets API RP 551 requirements for pressure measurement

Product Features

- Excellent load-cycle stability and shock resistance
- All stainless steel construction

Specifications

Design

ASME B40.100 & EN 837-1

Sizes

4½" (115 mm)

Accuracy class

± 0.5% of span (ASME B40.100 Grade 2A)

Ranges

Vacuum / Compound to 200 psi (16 bar)
Pressure from 0/15 psi (1 bar) to 0/15,000 psi (1,000 bar)
or other equivalent units of pressure or vacuum

Working pressure

Steady: full-scale value
Fluctuating: 0.9x full-scale value
Short time: 1.3x full-scale value

Operating temperature

Ambient: -40°F to +140°F (-40°C to +60°C) - dry
-4°F to +140°F (-20°C to +60°C) - glycerine-filled
-40°F to +140°F (-40°C to +60°C) - silicone-filled
Medium: +392°F (+200°C) maximum - dry
+212°F (+100°C) maximum - liquid-filled



Bourdon Tube Pressure Gauge Model 232.50, 4½"

Temperature error

Additional error when temperature changes from reference temperature of 68°F (20°C) ±0.4% of span for every 18°F (10°K) rising or falling.

Weather protection

Weather tight (NEMA 4X / IP65)

Pressure connection

Material: 316L stainless steel
Lower mount (LM) or lower back mount (LBM)
½" NPT (other connections available)

Bourdon tube

Material: 316 stainless steel
> 1,000 psi (100 bar): C-shape
≤ 1,500 psi (100 bar): helical

Movement

Stainless steel

Dial

White aluminum with black lettering

Pointer

Black aluminum, adjustable

Case

- 304 Stainless steel with blow out plug on back of case and fill plug on top of case
- For pressure ranges ≤ 300 psi, case has compensating valve/fill plug to vent case pressure

Bezel ring

Stainless steel, bayonet-type

Window

Safety Glass with Buna-N gasket

Case fill

Glycerine 99.7% - Type 233.50

Optional extras

- Other pressure connections
- Restrictor for high dynamic pressure pulsations
- Front flange, SS (LBM only)
- Rear flange, SS
- Silicone or Halocarbon case filling
- Red drag pointer or mark pointer
- Custom dial layout
- Other pressure scales available: bar, kPa, MPa, kg/cm² and dual scales
- NACE compliance
- Acrylic (PMMA) window

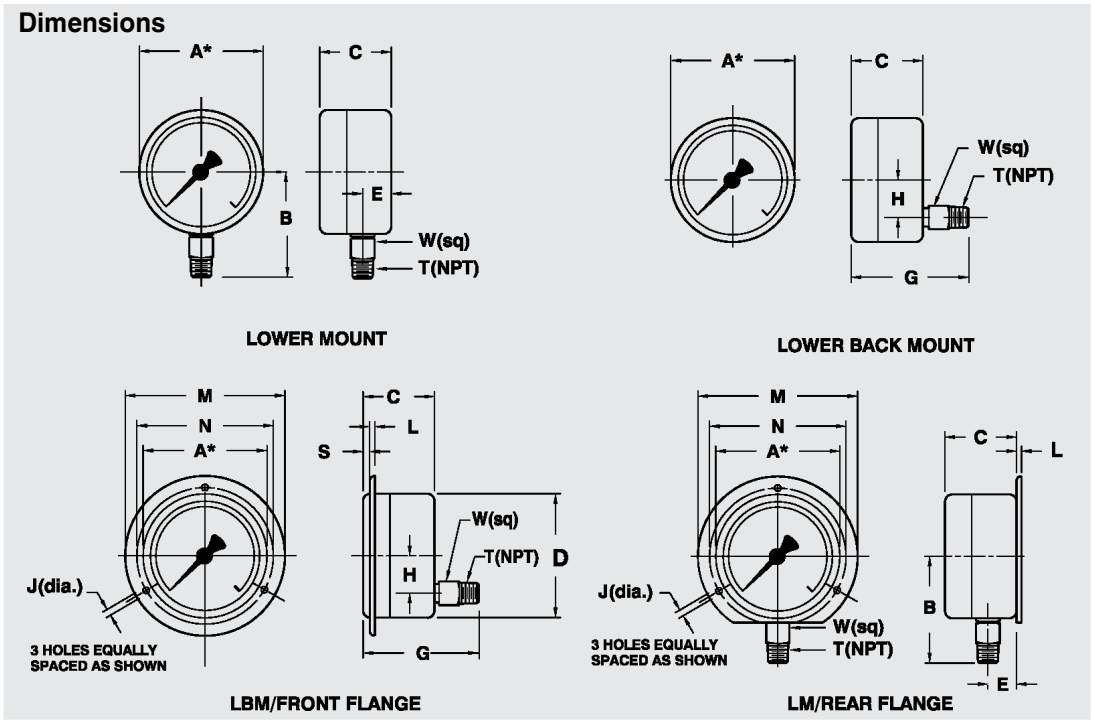

Size		A	B	C	D ²	E	G	H	J	L	M	N	S	T	W	Weight ¹	
4½"	mm	121	97	49.5	119	15.5	83	30	5	3	148	137	5	22	1.76 lb.	dry	
	in	4.76	3.82	1.95	4.68	0.61	3.27	1.18	0.2	0.12	5.83	5.39	0.20	1/2"	0.87	3.08 lb.	filled

¹ Weight without optional accessories
² D (+) 1mm for panel cutout

Ordering information
 Pressure gauge model / Nominal size / Scale range / Size of connection / Optional extras required
 Specifications and dimensions given in this leaflet represent the state of engineering at the time of printing.
 Modifications may take place and materials specified may be replaced by others without prior notice.



WIKAL Instrument Corporation
 1000 Wiegand Boulevard
 Lawrenceville, GA 30045
 Tel (770) 513-8200 Toll-free 1-888-WIKA-USA
 Fax (770) 338-5118
 E-Mail info@wika.com
 www.wika.com