



Pocket Test Thermometers

Pocket Case and Clip

Type TI.1005

Thermometers

Application

Food processing, testing, automotive, HVAC/R

Size

1" (25.4mm) - Type TI.1005

Accuracy

+/- 1% of full scale

Ranges

-40/160° F; 0/220° F; 50/550° F



Standard Features

Case

Stainless steel

Connection

Center Back Mount

Stem

Length = 5"

Diameter = .142"

Tip = pointed

Connection

Plain, 7/16"

External Adjustment

Hex hub

Dials

White coated aluminum with black markings

Pointer

Aluminum with matte red finish

Window

Lexan

Dimensions:

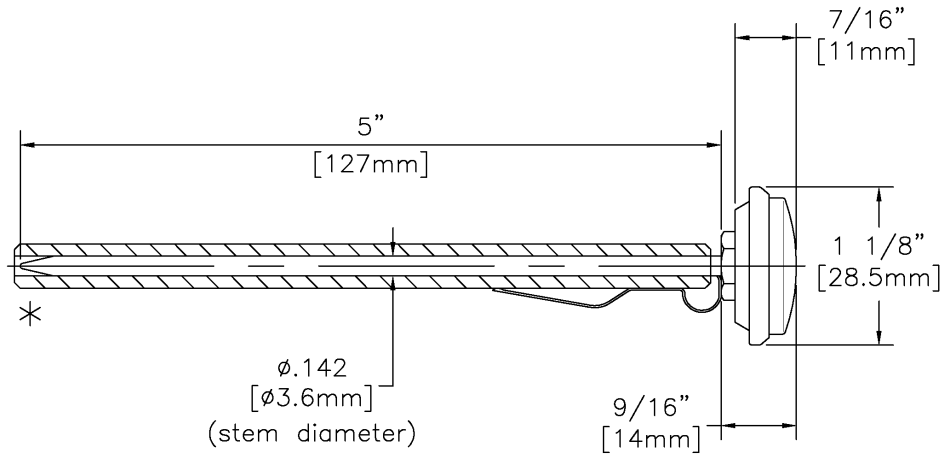

THE MEASURE OF
Total Performance™

Ordering Information:

State computer part number (if available) / type number / size / range / connection size and location / options required.

Specifications given in this price list represent the state of engineering at the time of printing. Modifications may take place and the specified materials may change without prior notice

01/03



WIKAI Instrument Corporation

1000 Wiegand Boulevard

Lawrenceville, Georgia 30043-5868

Tel: 770-513-8200 Fax: 770-338-5118

<http://www.wika.com> e-mail: info@wika.com