



TR10-2 Industrial RTD Assembly Spring Loaded (Head Internal)

TR10-2 resistance temperature detectors (RTDs) are industrial assemblies supplied with or without a temperature transmitter. An extensive range of elements, connection heads, insertion lengths and neck lengths can be individually selected for the appropriate application.

RTDs in this series are designed to fit into a variety of thermowell configurations. Spring loading is achieved within the termination head utilizing a self-gripping spring or spring loaded DIN plate.

Replacement sensors can also be configured for this model.

Features:

- The sensor is designed to be mounted into a thermowell.
- The assembly has electrical approvals for explosion proof hazardous locations, ingress protection and general purpose areas.
- Electrical authorities that have registered these approvals include CSA, FM and ATEX. The approvals can be with or without an attached thermowell. Our patented integral flame path fitting is required when supplied without a thermowell.
- The RTD sensor is spring-loaded ensuring a positive contact to the base of a thermowell bore.

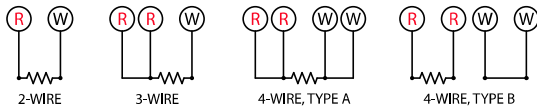

Connection Heads

Imperial Grid 1" x 1"

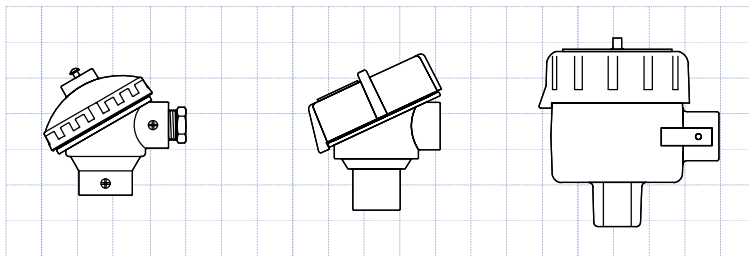

KN4-A
KN4-P

1/4000F
1/4000S

7/8000W

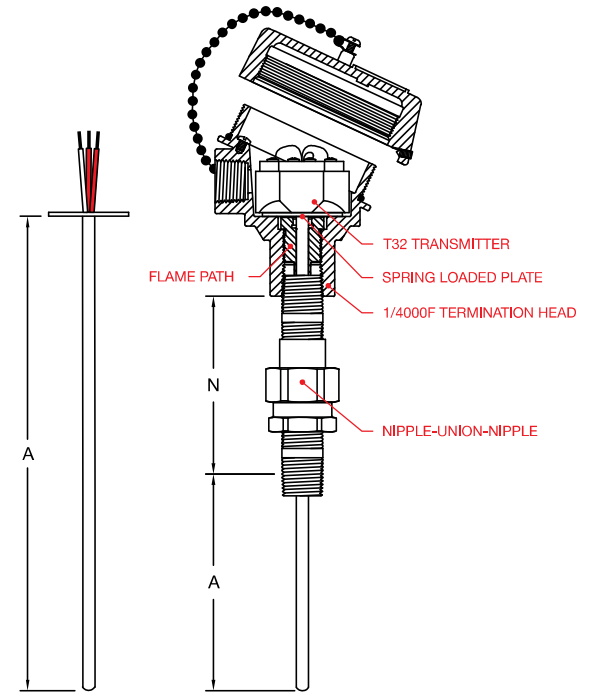

RTD ASSEMBLY SAMPLE
TR10-2-0-I-D-C-1AF13-6-FG-060-C-B-K-C-1-P-00600-Z

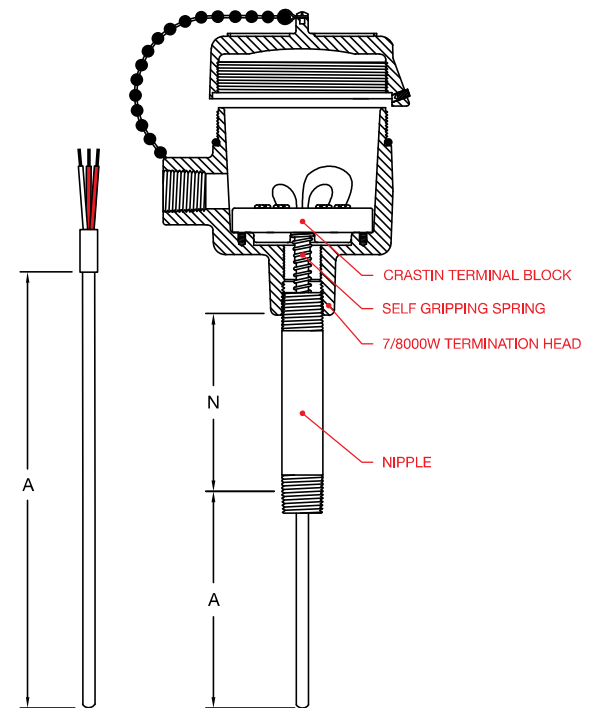

RTD ASSEMBLY SAMPLE
TR10-2-0-I-S-C-7AW13-1-EG-030-C-B-K-C-1-P-00600-Z